



**TBL/TBL plus
Plate clamp
with safety lock**

Capacity 500 - 3000 kg

This clamp is primarily used for transporting single steel plates in the vertical position, as well as lifting and turning through 180°. This clamp can also be used for transporting steel constructions and profiles. It is recommended to use a pair of plate clamps in conjunction with a spreader beam for large sized sheets and long materials which have a tendency to sag.

The jaw can be opened and closed with the locking lever (except for the TBL 0.5t which uses a positive spring-loaded cam). The safety lock overrides the spring-loaded cam, preventing the clamp from opening even when there is no load.

This plate clamp is service-friendly, making it easy to exchange parts, which are available individually or in kits. Clamp repair is available by the factory, or can be done by certified and experienced staff.

The TBL 0.5 is equipped with a safety lock (positive spring-loaded cam), but comes without locking lever.

INFO

The surface hardness of the material must not exceed HRC 30/Brinell 300.

The min. load is 10% of the nominal WLL. Except for model TBL 1,5 plus, the min. load here is 100 kg!

Technical data TBL/TBL plus

Model	Art.-No.	Capacity kg	Jaw capacity Z mm	Weight kg
TBL 0,5	N50100051	500	0 - 16	1.5
TBL 1,5 plus	N50100056	1500	0 - 20	3.0
TBL 2,0 plus	N50100057	2000	0 - 32	9.3
TBL 3,0 plus	N50100058	3000	0 - 32	9.3

Dimensions TBL/TBL plus

Model	TBL 0,5	TBL 1,5 plus	TBL 2,0 plus	TBL 3,0 plus
A, mm	99	126	192	192
B, mm	195	225	312	312
Ø C, mm	29	50	80	80
D, mm	33	49	75	75
E, mm	47	70	96	96
F, mm	50	82	100	100
G, mm	48	55	81	81
H, mm	11	12	20	20
I, mm	16	20	24	24

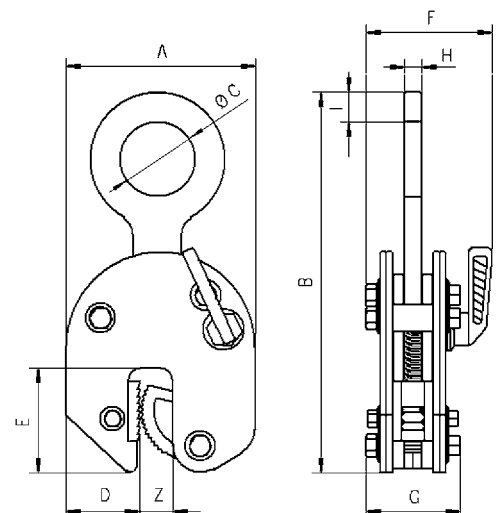

TBL
Plate clamp
with safety lock

Capacity 4000 - 30000 kg

This clamp is primarily used for transporting single steel plates in the vertical position, as well as lifting and turning through 180°. This clamp can also be used for transporting steel constructions and profiles. It is recommended to use a pair of plate clamps in conjunction with a spreader beam for large sized sheets and long materials which have a tendency to sag.

These plate clamps have the same design and applications as the clamp model TBL with a capacity from 500 - 3000 kg.



INFO

The surface hardness of the material must not exceed HRC 30/Brinell 300.

The min. load is 10% of the nominal WLL!

Technical data TBL

Model	Art.-No.	Capacity kg	Jaw capacity Z mm	Weight kg
TBL 4,0 S	N50100005	4000	0 - 32	11.2
TBL 4,0 L	N50100006	4000	30 - 60	11.9
TBL 6,0 S	N50100021	6000	0 - 50	20.6
TBL 6,0 L	N50100008	6000	50 - 100	23.2
TBL 8,0 S	N50100022	8000	0 - 50	24.2
TBL 8,0 L	N50100023	8000	50 - 100	28.8
TBL 10,0 S	N50100024	10000	0 - 50	29.5
TBL 10,0 L	N50100025	10000	50 - 100	35.1
TBL 15,0 S	N50100015	15000	0 - 50	76.0
TBL 15,0 L	N50100016	15000	50 - 100	86.0
TBL 20,0 S	N50100017	20000	0 - 65	123.0
TBL 20,0 L	N50100018	20000	65 - 130	135.0
TBL 30,0 S	N50100019	30000	0 - 65	195.0
TBL 30,0 L	N50100020	30000	65 - 130	256.0

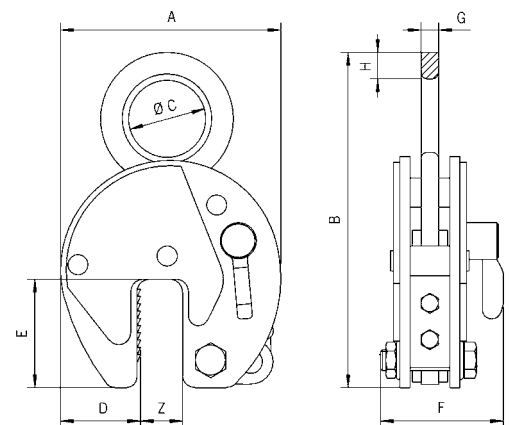

Dimensions TBL

Model	TBL 4,0 S	TBL 4,0 L	TBL 6,0 S	TBL 6,0 L	TBL 8,0 S	TBL 8,0 L	TBL 10,0 S	TBL 10,0 L	TBL 15,0 S	TBL 15,0 L	TBL 20,0 S	TBL 20,0 L	TBL 30,0 S	TBL 30,0 L
A, mm	197	228	293	362	293	362	293	362	360	460	462	560	462	560
B, mm	339	339	442	482	450	482	503	503	550	615	674	724	667	732
Ø C, mm	80	80	89	89	89	89	110	110	130	130	130	130	60	60
D, mm	68	68	95	114	95	114	95	114	125	175	165	195	165	195
E, mm	93	100	143	143	143	143	143	143	162	162	210	210	210	210
F, mm	110	110	129	129	129	129	139	139	204	204	235	235	295	295
G, mm	20	20	20	20	20	20	25	25	45	45	45	45	65	65
H, mm	32	32	35	35	42	42	45	45	55	55	65	65	66	67



**TBS plus
Plate clamp
with hinged hook ring and
safety lock**

Capacity 1000 - 3000 kg

The TBS plate clamp with hinged hook ring can be used for the safe handling of plates at various angles. It can lift plates from the horizontal and put down in the vertical or alternatively lift it over the edge by gripping it from the side. The hinged hook ring ensures adequate clamping force in every position. Depending on the angle of usage capacity restrictions have to be taken into account, as shown in the diagram below.

The hinged hook ring has the added advantage of providing enough clamping force to hold a plate safely. Even when transporting large-sized plates with the 2-legged lifting system slipping of the load and damage to the clamp is avoided.

In addition to transporting plates, this clamp is suitable for turning steel structures and welded constructions.

INFO

The surface hardness of the material must not exceed HRC 30/Brinell 300.

The min. load is 10% of the nominal WLL!

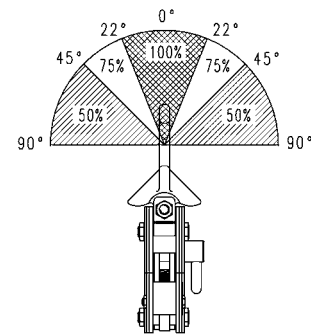

Technical data TBS plus

Model	Art.-No.	Capacity kg	Jaw capacity Z mm	Weight kg
TBS 1,0 plus	N50200312	1000	0 - 20	3.2
TBS 2,0 plus	N50200313	2000	0 - 32	9.4
TBS 3,0 plus	N50200314	3000	0 - 32	9.4

Dimensions TBS plus

Model	TBS 1,0 plus	TBS 2,0 plus	TBS 3,0 plus
A, mm	126	192	192
B, mm	270	382	382
Ø C, mm	50	80	80
D, mm	49	75	75
E, mm	70	96	96
F, mm	95	132	132
G, mm	63	92	92
H, mm	12	20	20
I, mm	23	30	30

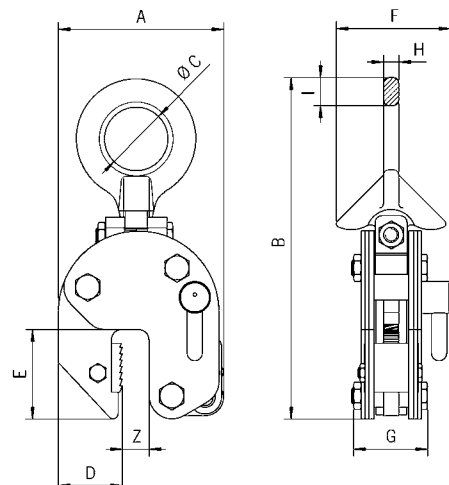

TBS
Plate clamp
with pivoting shackle and
safety lock

Capacity 4500 - 10000 kg



INFO

The surface hardness of the material must not exceed HRC 30/Brinell 300.

The min. load is 10% of the nominal WLL!

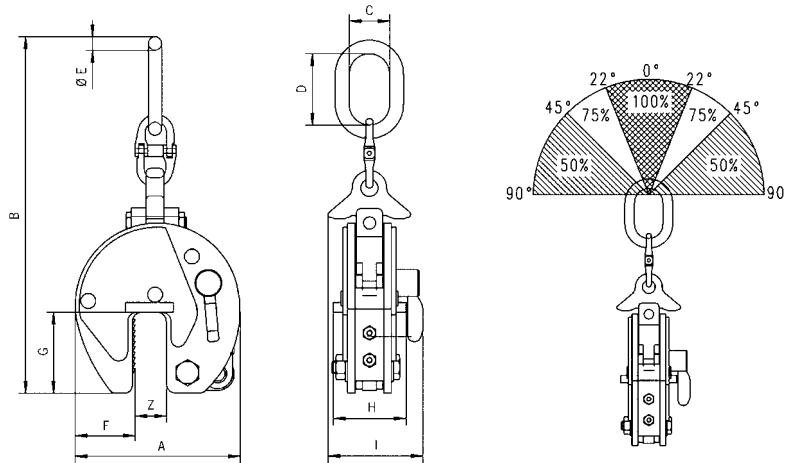

Technical data TBS

Model	Art.-No.	Capacity kg	Jaw capacity Z mm	Weight kg
TBS 4,5	N50200309	4500	0 - 50	34.4
TBS 6,0 S	N50200305	6000	0 - 50	38.0
TBS 6,0 L	N50200306	6000	50 - 100	42.0
TBS 8,0 S	N50200307	8000	0 - 50	39.0
TBS 8,0 L	N50200310	8000	50 - 100	42.4
TBS 10,0 S	N50200308	10000	0 - 50	68.0
TBS 10,0 L	N50200311	10000	50 - 100	80.0

Dimensions TBS

Model	TBS 4,5	TBS 6,0 S	TBS 6,0 L	TBS 8,0 S	TBS 8,0 L	TBS 10,0 S	TBS 10,0 L
A, mm	292	292	367	292	367	360	446
B, mm	675	737	785	737	785	903	921
C, mm	95	95	98	98	98	110	112
D, mm	180	176	180	176	180	195	195
Ø E, mm	27.8	27.8	27.8	27.8	27.8	33	33
F, mm	95	95	115	95	115	125	168
G, mm	143	143	143	143	143	162	162
H, mm	135	137	135	136	136	170	170
I, mm	185	188	188	210	210	223	223



TAG

Universal grab

Capacity 350 - 5000 kg

TWG

-with modified side plates

Capacity 750 - 1250 kg

The universal grabs TAG and TWG save time, as it does not require chains, cables etc. when hoisting and loading material.

The large jaw capacity allows to tackle a variety of sizes with only one clamp. It can be used for loading machine tools, lifting steel constructions, welding and assembly jobs as well as for concrete and prefabricated pieces.

The universal grab with a small outside measurement is a specially designed grab for use on hard to reach places (e.g. lathe machine).

Features

- The automatic clamping force is retained by a positive tension spring, even if there is slack in the chain.
- The "Quick-Open" type universal grab opens by lifting and simultaneously pulling the lever out against the tension spring. The jaw is closed by the spring.
- Universal grabs up to 2.0t capacity are equipped with round chains, clamps with increased capacities are delivered with roller chains.

Option

- Model TAG up to 1.25t WLL is available with protective lining on the clamping jaws on request. This results in a decrease of the jaw capacity by 10 mm.

INFO

The surface hardness of the material must not exceed HRC 30/Brinell 300.

The min. load is 10% of the nominal WLL!



TWG with modified side plates for use in confined spaces (e.g. lathe machine).

Technical data TAG

Model	Art.-No.	Capacity kg	Jaw width mm	Jaw capacity mm	Weight kg
TAG 0,35/100	N50300801	350	100	0 - 100	8.7
TAG 0,35/200	N50300802	350	200	90 - 200	16.3
TAG 0,75/100	N50300803	750	100	0 - 100	8.6
TAG 0,75/200	N50300804	750	200	90 - 200	16.6
TAG 1,25/100	N50300805	1250	100	0 - 100	14.9
TAG 1,25/200	N50300806	1250	200	90 - 200	24.3
TAG 2,0/100	N50300807	2000	100	0 - 100	20.8
TAG 2,0/200	N50300808	2000	200	90 - 200	29.1
TAG 3,0/90	N50300809	3000	90	5 - 90	26.5
TAG 5,0/90	N50300810	5000	90	5 - 90	30.5
TAG 5,0/170	N50300811	5000	170	80 - 170	43.8

Technical data TWG

Model	Art.-No.	Capacity kg	Jaw width mm	Jaw capacity mm	Weight kg
TWG 0,75/100	N50300821	750	100	30 - 100	11.0
TWG 1,25/100	N50300822	1250	100	30 - 100	16.0

Dimensions TAG

Model	TAG 0,35/100	TAG 0,35/200	TAG 0,75/100	TAG 0,75/200	TAG 1,25/100	TAG 1,25/200	TAG 2,0/100	TAG 2,0/200	TAG 3,0/90	TAG 5,0/90	TAG 5,0/170
A, mm	264	382	264	382	320	382	328	375	297	297	354
B, mm	259	434	259	434	289	434	415	515	290	290	423
C, mm	128	195	128	195	128	195	135	195	136	136	180
D, mm	100	156	100	156	100	156	115	165	106	106	155
E, mm	100	200	100	200	100	200	100	200	90	90	170
F, mm	85	120	85	120	85	120	105	160	91	91	118
G, mm	550	760	550	760	570	760	571	750	570	570	620
H, mm	75	75	75	75	75	75	75	75	82	82	82
I, mm	121	121	121	121	121	121	121	121	111	111	111
J, mm	20	20	20	20	20	20	20	20	32	32	32
K, mm	78	90	83	90	83	90	105	105	137	147	147

Dimensions TWG

Model	TWG 0,75/100	TWG 1,25/100
A, mm	264	320
B, mm	209	255
C, mm	128	128
D, mm	100	100
E, mm	100	100
F, mm	35	51
G, mm	550	570
H, mm	75	75
I, mm	121	121
J, mm	20	20
K, mm	83	83

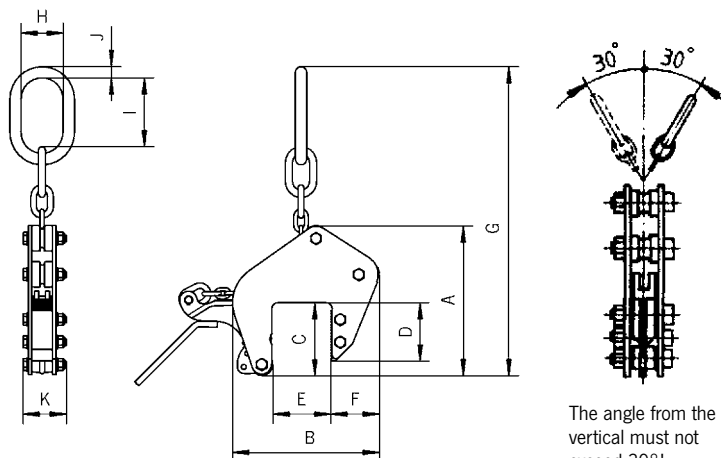

TIGRIP® T-MAG

Permanent load lifting magnet

Capacity

125 - 2000 kg (Flat material),
50 - 1000 kg (Round material)

The permanent lifting magnets of the T-MAG series are ideal for the simple, fast and therefore economical transport of heavy workpieces made of ferromagnetic material. The use of high-quality neodymium material enables a large lifting force with a low dead weight.

Both flat and round materials can be picked up. The load is not influenced mechanically. After switching off, there is only a small amount of residual magnetism.

Thanks to the simple Easy Switch operation, the lifting magnet can be switched over quickly and safely with just one hand. This reliable system enables not only safe and practical, but also faster work with up to 40% time savings.

When activated, the operating lever is locked by a safety lock so that unintentional demagnetization is prevented.

Features

- The simple "EASY SWITCH" enables one-hand operation.
- Extremely robust and compact design
- Easy to maintenance and service
- Low dead weight
- Low residual magnetism after switch-off
- High temperature range up to max. 80 °C
- Made in EU
- Safety factor 3:1 according to DIN EN 13155



"Easy Switch"
**ALLOWS SINGLE-HANDED
OPERATION**



INFO

The selection of the appropriate magnet model should be made under consideration of the varying conditions of the contact surface, kind of material alloy, ambient temperature and plate thickness.

For further information, please have a look into the manual.

DIVERSE POSSIBILITIES OF APPLICATION

The areas of application of this load handling device are very diverse and range from typical workshop applications to aligning tools in machining centers to rough use in steelworks, shipyards and even offshore.



Technical data T-MAG

Model	Art.-No.	Flat material			Round material			Test load	Weight
		Capacity ¹ max.	Material thickness min. at max. capacity	Length of material max.	Capacity ¹ max.	Diameter min. - max.	Length of material max.		
		kg	mm	mm	kg	mm	mm	kg	kg
T-MAG 125	192047639	125	25	2500	65	50 - 100	2500	375	3
T-MAG 250	192047640	250	30	3500	125	60 - 200	3500	750	10
T-MAG 500	192047641	500	40	4000	250	65 - 270	4000	1500	21
T-MAG 1000	192047642	1000	60	4500	500	100 - 300	4500	3000	40
T-MAG 2000	192047643	2000	80	5000	1000	150 - 350	5000	6000	90

¹ Measured on bright drawn material S235JR (ST37), air gap <0,1 mm

Dimensions T-MAG

Model	T-MAG 125	T-MAG 250	T-MAG 500	T-MAG 1000	T-MAG 2000
A, mm	93	152	246	306	478
B, mm	60	100	120	146	165
C, mm	120	180	180	236	273
D, mm	125	182	185	225	265

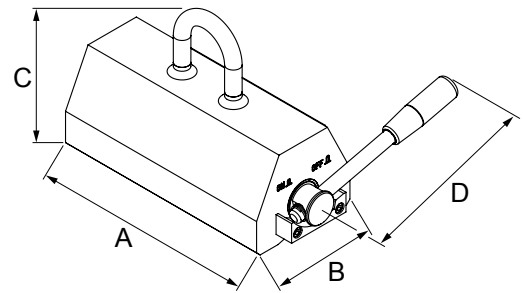

INFO

In order to achieve a maximum capacity, the contact surface should be bright and free from dirt, oil, grease, scale, corrosion, paint etc.





TPM

Permanent load lifting magnet

Capacity

100 - 3000 kg (Flat material)

50 - 1500 kg (Round material)

TPM load lifting magnets are ideal tools for easy, quick and thus economical transport of heavy objects made of ferro-magnetic material. Typical operating areas are workshops and warehouses, loading and unloading of machines as well as construction of jigs and fixtures.

Compact design of the units for a large number of applications.

The load is not affected mechanically which allows lifting of flat as well as round material. The efficient magnet body provides strong lifting capacity at low dead weight. The permanent magnets do not require electric energy and will leave only minor residual magnetism on the material after use.

The magnets are activated/deactivated easily by turning a locking lever. In activated condition the hand lever will be safely locked and thus prevent unintended demagnetising.

The selection of the appropriate magnet model should be made under consideration of the varying conditions of the contact surface, kind of material alloy and plate thickness/bar diameter (see table).

INFO

In order to achieve a maximum capacity, the contact surface should be bright and free from dirt, oil, grease, scale, corrosion, paint etc.



Technical data TPM

Model	Art.-No.	Flat material			Capacity ¹ max. kg	Round material		Test load kg	Weight kg
		Capacity ¹ max. kg	Material thickness min. at max. capacity mm	Length of material max. mm		Diameter min. - max. mm	Length of material max. mm		
TPM 0,1	N56400001	100	14	2000	50	40 - 300	2000	300	5.3
TPM 0,3	N56400002	300	20	2500	150	60 - 300	2500	900	13.5
TPM 0,5	N56400003	500	24	3000	250	60 - 400	3000	1500	27.5
TPM 0,8	N56400004	800	34	3500	400	60 - 400	3500	2400	52.0
TPM 1,0	N56400005	1000	40	3500	500	80 - 400	3500	3000	57.0
TPM 2,0	N56400006	2000	55	3500	1000	100 - 400	3500	6000	125.0
TPM 3,0	192019927	3000	65	3500	1500	200 - 500	3500	9000	195.0

¹ Measured on bright drawn material S235JR (ST 37), air gap <0,1 mm

Dimensions TPM

Model	TPM 0,1	TPM 0,3	TPM 0,5	TPM 0,8	TPM 1,0	TPM 2,0	TPM 3,0
A, mm	122	192	232	302	332	392	497
B, mm	69	95	120	154	154	196	220
C, mm	185	225	270	320	320	420	453
D, mm	160	250	250	450	450	450	600

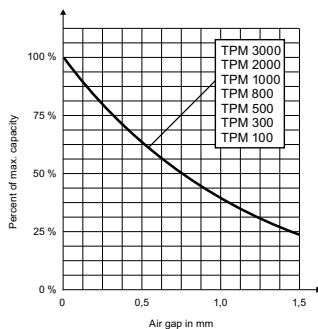

Diagram: WLL/air gap

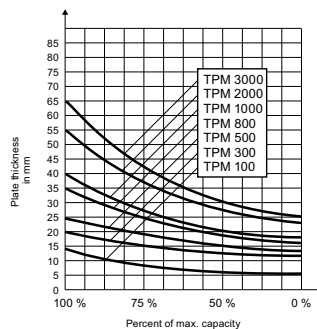
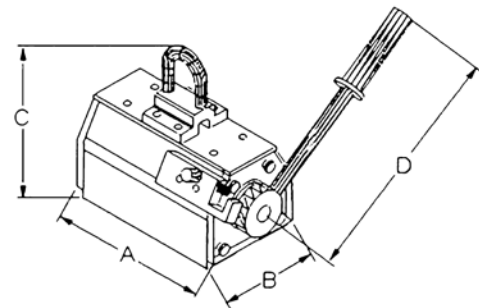
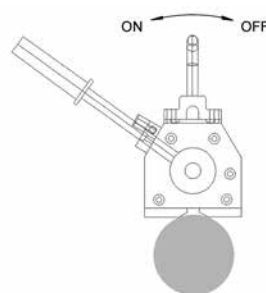
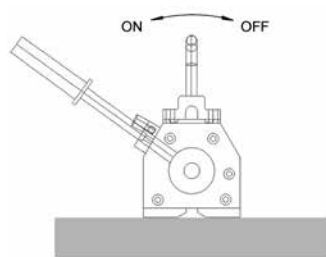

Diagram: WLL/material thickness



TPM



Correct use On/Off

Reduction of capacity	% of capacity
Temperature ≤ 60 °C	100 %
Humidity ≤ 80 %	100 %
St 52	95 %
Alloy steel	80 %
High carbon steel	70 %
Cast iron	45 %
Nickel	10 %
Austenitic, stainless steel	0 %
Brass	0 %
Aluminium	0 %





TBP

Non-marring grab

Capacity 500 - 1500 kg

The TBP non-marring grab is suitable for lifting, turning and transporting of plates with a sensitive surface without leaving behind indentations.

It can be used for aluminium and stainless steel plate or those with an extremely hard surface.

INFO

The surface of the plate must be free of oil, grease or any other liquid to ensure safe transport.

The min. load is 10% of the nominal WLL!

Temperature range from -20 °C up to +60 °C

Technical data TBP

Model	Art.-No.	Capacity kg	Jaw capacity Z mm	Weight kg
TBP 0,5	N51502419	500	0 - 10	3.0
TBP 1,5	N51502420	1500	0 - 20	12.6

Dimensions TBP

Model	TBP 0,5	TBP 1,5
A, mm	127	215
B, mm	200	345
D, mm	52	75
E, mm	69	135
F, mm	87	131
G, mm	76	118
H, mm	13	20
I, mm	20	24
Ø C, mm	55	85

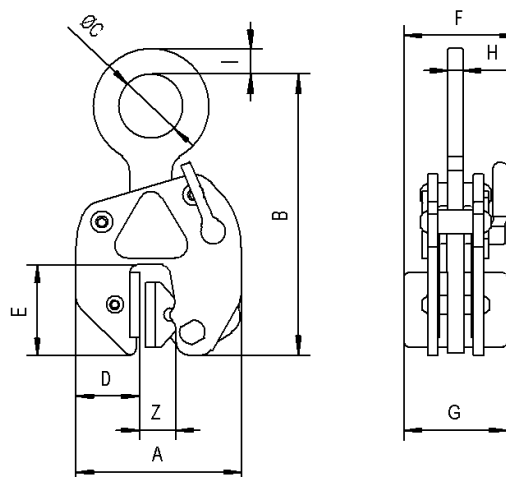

TSB

Non-marring grab with chain

Capacity 750 - 1250 kg

The TSB grab has parallel-facing jaws that equally distribute the clamping pressure over a relatively large surface area. This makes the grab attractive for plate material with sensitive surfaces. The protective lining "Bremsit" offers an outstanding friction coefficient, thereby enhancing the grip of the jaws. This lining can be easily replaced when worn.

Similar to the universal grab, this grab has a large jaw capacity and the security of a safety lock device with a hold-open/hold-closed feature.



INFO

The surface of the plate must be free of oil, grease or any other liquid to ensure safe transport.

The min. load is 10% of the nominal WLL!

Temperature range from -20 °C up to +60 °C

Technical data TSB

Model	Art.-No.	Capacity kg	Jaw capacity Z mm	Weight kg
TSB 0,75/65	N51202202	750	0 - 65	11.8
TSB 1,25/65	N51202203	1250	0 - 65	16.7

Dimensions TSB

Model	TSB 0,75/65	TSB 1,25/65
A, mm	272	330
B, mm	260	280
C, mm	128	128
D, mm	100	100
E, mm	79	90
F, mm	78	90

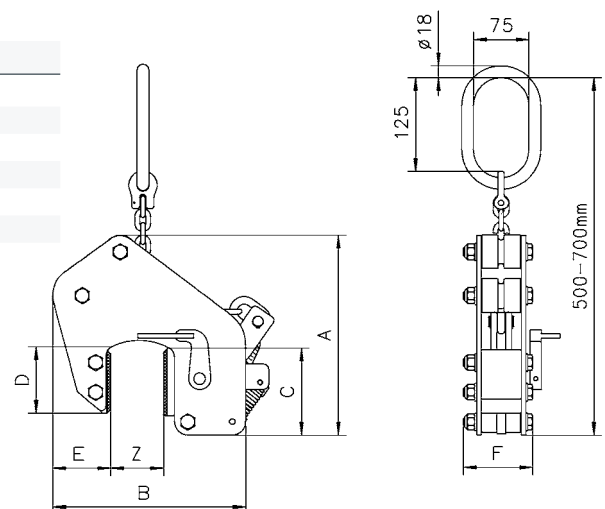



TTG Girder grab for horizontal transport

Capacity 500 - 7500 kg

The girder grab TTG is designed for the horizontal transport of girders, metal plates, profiles etc. The offset suspension lug ensures that the flange of the girder will be kept practically horizontal during transport.

The positive safety lock keeps the clamp safely locked, even before the lift begins. This allows the operator to place the clamp, lock it closed and move away from the load. The lever ensures easy opening and closing of the clamping jaw and has a "lock open" feature.

INFO

When transporting long girders, it is recommended to use a pair of clamps in conjunction with a spreader beam.

Technical data TTG

Model	Art.-No.	Capacity kg	Jaw capacity mm	Weight kg
TTG 0,5	N50901950	500	0 - 20	2.9
TTG 1,5	N50901951	1500	0 - 30	6.8
TTG 3,0	N50901952	3000	0 - 35	11.3
TTG 4,5	N50901953	4500	0 - 40	14.8
TTG 7,5	N50901954	7500	0 - 45	30.0

Dimensions TTG

Model	TTG 0,5	TTG 1,5	TTG 3,0	TTG 4,5	TTG 7,5
Ø A, mm	50	70	80	90	110
B, mm	36	43	55	60	64
C, mm	25	35	42	46	55
D, mm	148	140	180	196	222
E, mm	200	180	214	248	304
F, mm	27	40	40	40	50
G, mm	20	30	32	35	42
H, mm	95	155	190	207	237
I, mm	110	230	284	314	367
J, mm	10	15	20	20	22
K, mm	56	50	60	64	90
L, mm	85	100	114	117	143
M, mm	13	16	20	25	30

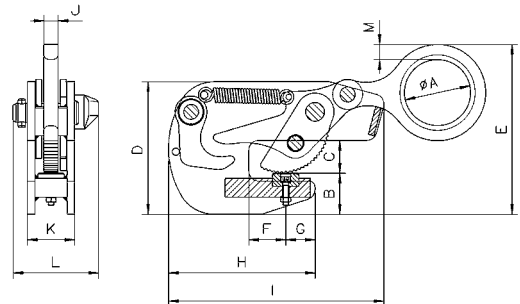

TTR
Girder grab
for vertical transport

Capacity 750 - 3000 kg

The girder grab TTR is designed for vertical transport, especially for lifting and stacking of girders. The unique position of the offset suspension lug keeps the girder virtually in a vertical position during transport.

The positive safety lock keeps the clamp safely locked, even before the lift begins. This allows the operator to place the clamp, lock it closed and move away from the load. The lever ensures easy opening and closing of the clamping jaw and has a “lock open” feature.



INFO

When transporting long girders, it is recommended to use a pair of clamps in conjunction with a spreader beam.

Technical data TTR

Model	Art.-No.	Capacity kg	Jaw capacity mm	Weight kg
TTR 0,75	N51702551	750	5 - 16	3.1
TTR 1,50	N51702552	1500	5 - 25	6.8
TTR 3,00	N51702553	3000	5 - 28	10.9

Dimensions TTR

Model	TTR 0,75	TTR 1,50	TTR 3,00
A, mm	24	33	37
B, mm	40	53	56
C, mm	132	176	194
D, mm	62	76	78
E, mm	145	190	208
F, mm	118	152	163
Ø G, mm	50	70	80
H, mm	12	15	20
I, mm	12	17	23
K, mm	53	69	85

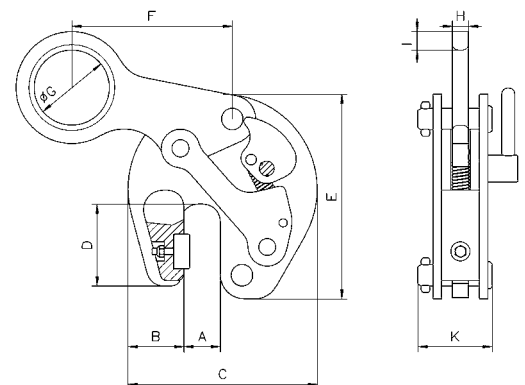



TTT Girder grab for horizontal transport

Capacity 750 - 4500 kg

The girder grab TTT is used for the horizontal transport of steel girders. Due to the split fixed jaw, it can be positioned centrally on the end of the beam. The grab should only be used in pairs.

The safety lock with positive spring tension holds the grab in position on the end of the girder even without load tension.

The lever is used to engage and disengage the jaw and to keep it open.

INFO

The angle from the vertical must not exceed 30°!

Technical data TTT

Model	Art.-No.	Capacity kg	Jaw capacity mm	Weight kg
TTT 0,75	N54509121	750	0 - 20	3
TTT 1,5	N54509122	1500	0 - 35	6
TTT 3,0	N54509123	3000	0 - 40	10
TTT 4,5	N54509124	4500	0 - 45	16

Dimensions TTT

Model	TTT 0,75	TTT 1,5	TTT 3,0	TTT 4,5
A, mm	30	38	50	60
B, mm	70	70	75	90
C, mm	100	155	195	222
D, mm	142	150	195	222
Ø E, mm	50	70	80	90
F, mm	16	19	19	22
G, mm	16	20	25	30
H, mm	225	335	400	450
I, mm	45	45	80	90
J, mm	200	210	214	248
K, mm	106	120	125	147
L, mm	52	66	80	88

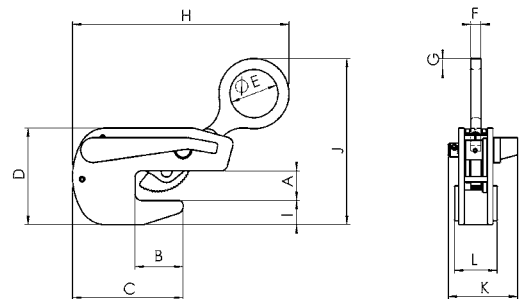

TCH Horizontal lifting gear

Capacity 1000 - 20000 kg

The TCH lifting clamp is designed to be used as a pair with a two-legged chain sling.

It is especially suited for the transport of single plates with a minimum thickness of approx. 5 mm as well as for plate bundles. The two-legged version is appropriate for normal sized plates.

For extra large or long plates, it is recommended to use two sets of the two-legged lifting gears in conjunction with a spreader beam. In the standard version, the lifting clamp is suitable for plates up to 1500 mm width. Lifting gears with longer chains for larger plate widths are available on request.



Similar image

INFO

The angle from the vertical must not exceed 45°!

The capacity applies to a pair of lifting clamps.

Technical data TCH

Model	Art.-No. single clamp	Capacity ¹ kg	Jaw capacity mm	Weight ² kg
TCH 1,0	N50501517	1000	0 - 50	13.0
TCH 2,0	N50501511	2000	5 - 32	17.7
TCH 4,0	N50501512	4000	5 - 50	31.0
TCH 6,0	N50501513	6000	5 - 75	69.0
TCH 8,0	N50501514	8000	5 - 75	72.0
TCH 10,0/1	N50501515	10000	5 - 100	93.8
TCH 10,0/2	N50501516	10000	50 - 150	108.6
TCH 15,0/1	N4300012878	15000	5 - 100	110
TCH 15,0/2	N4300012879	15000	50 - 150	123
TCH 20,0/1	N4300014489	20000	5 - 100	165
TCH 20,0/2	N4300014491	20000	50 - 150	172

¹ Per pair, up to an angle of 45° from the vertical

² Approx. weight for 2 single clamps with a chain length = 1 m

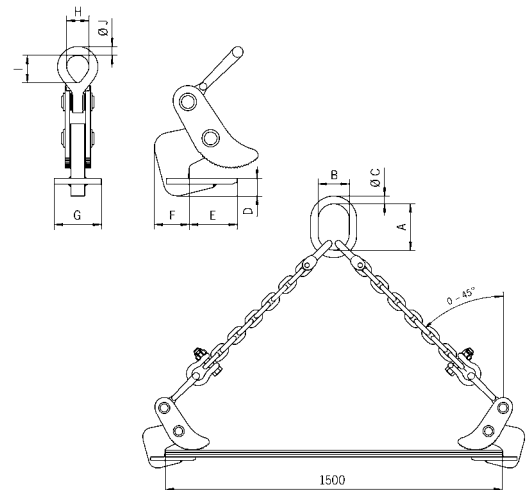

Dimensions TCH

Model	TCH 1,0	TCH 2,0	TCH 4,0	TCH 6,0	TCH 8,0	TCH 10,0/1	TCH 10,0/2	TCH 15,0/1	TCH 15,0/2	TCH 20,0/1	TCH 20,0/2
A, mm	135	160	180	200	260	300	300	-	-	-	-
B, mm	75	90	100	110	140	160	160	-	-	-	-
Ø C, mm	18	22	26	32	36	40	40	-	-	-	-
D, mm	15	32	44	58	56	70	66	71	71	70	70
E, mm	82	83	114	172	170	216	218	230	230	220	220
F, mm	65	61	75	97	100	116	116	120	120	118	118
G, mm	100	100	99	129	128	149	150	150	150	220	220
H, mm	32	49	62	90	90	113	113	144	144	80	80
I, mm	44	72	89	127	130	113	113	144	144	120	120
Ø J, mm	13	19	26	36	37	50	50	50	50	60	60



TGF Horizontal lifting gear

Capacity 1300 - 10000 kg

The TGF horizontal lifting gear consists of two clamps with a two-legged chain sling and is especially suited for the transport of plate bundles.

The clamps are easily adjusted to the height of the plate by a special ratcheting lever.

The lifting clamps are available in special versions for bundle thicknesses up to 400 mm. The lifting gear is made according to your requirements

INFO

The angle from the vertical must not exceed 45°!

The capacity applies to a pair of lifting clamps.

Technical data TGF

Model	Art.-No. single clamp	Capacity ¹ kg	Jaw capacity Z mm	Weight ² kg
TGF 1,3/150	N50601617	1300	0 - 150	23
TGF 3,3/150	N50601619	3300	0 - 150	39
TGF 6,6/150	N50601621	6650	0 - 150	65
TGF 1,3/250	N50601624	1300	0 - 250	23
TGF 3,3/250	N50601626	3300	0 - 250	39
TGF 6,6/250	N50601628	6650	0 - 250	87
TGF 10,0/300	192065646	10000	0 - 300	92

¹ Per pair, up to an angle of 45° from the vertical

² Approx. weight for 2 single clamps with a chain length = 1 m

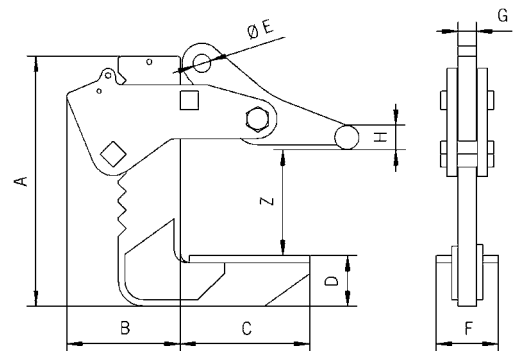

Dimensions TGF

Model	TGF 1,3/150	TGF 3,3/150	TGF 6,6/150	TGF 1,3/250	TGF 3,3/250	TGF 6,6/250	TGF 10,0/300
A, mm	298	321	405	448	417	495	495
B, mm	122	130	185	122	130	185	210
C, mm	160	160	210	140	160	210	240
D, mm	41	50	82	41	60	82	100
Ø E, mm	20	23	30	20	23	30	40
F, mm	80	80	100	80	80	100	120
G, mm	20	25	30	20	25	30	50
Ø H, mm	25	25	40	25	25	40	40

BVH Horizontal lifting hook

Capacity 500 - 7500 kg

The BVH horizontal lifting hooks are used in pairs with chain or wire rope slings to lift plate bundles that are relatively close to the ground.

The high tensile hooks have a serrated lifting surface.



INFO

The angle from the vertical must be 30 - 45°!

The chain has to be in line with the crank of the lifting hooks.

Technical data BVH

Model	Art.-No.	Capacity ¹ kg	Weight kg
BVH 0,5	N50500001	500	1.2
BVH 1,12	N50500002	1120	1.4
BVH 1,5	N50500003	1500	2.4
BVH 2,0	N50500004	2000	3.9
BVH 2,5	N50500005	2500	8.2
BVH 3,2	N50500006	3200	8.3
BVH 4,0	N50500007	4000	13.6
BVH 5,3	N50500008	5300	21.0
BVH 6,0	N50500009	6000	39.0
BVH 7,5	N50500010	7500	60.0

¹ Pro Stück

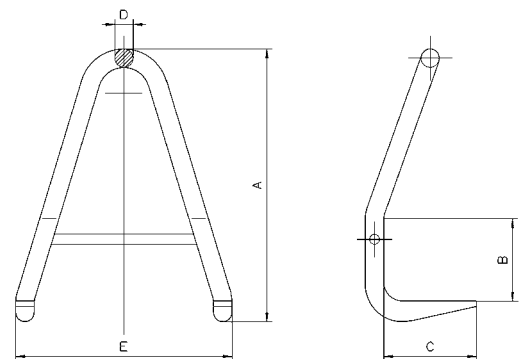

Dimensions BVH

Model	BVH 0,5	BVH 1,12	BVH 1,5	BVH 2,0	BVH 2,5	BVH 3,2	BVH 4,0	BVH 5,3	BVH 6,0	BVH 7,5
A, mm	180	210	240	280	340	400	530	660	800	980
B, mm	50	60	70	80	100	120	160	200	250	300
C, mm	80	95	105	115	120	140	180	210	250	300
D, mm	18	20	22	26	32	32	36	40	50	60
E, mm	150	170	200	220	270	320	420	520	640	760



THS Lifting clamp with safety lock

Capacity 750 - 4500 kg

The THS lifting clamp is normally used in pairs especially for the horizontal transport of plates. The transport of slightly sagging plates is also possible. Individually, it can be used to load presses shears, and other machines. The safety lock is preventing the clamp from opening, even when there is no load. The jaws can be opened and closed with the safety lock lever. This clamp has a lock-open feature.

Option

- THS 1.5 and THS 3.0 are available with a hinged hook ring on request.

INFO

When used in pairs the angle from the vertical must not exceed 30°!



Technical data THS

Model	Art.-No.	Capacity ¹ kg	Jaw capacity mm	Weight kg
THS 0,75	N50801851	750	0 - 20	3.2
THS 1,5	N50801852	1500	0 - 35	6.1
THS 3,0	N50801853	3000	0 - 40	12.7
THS 4,5	N50801854	4500	0 - 40	16.5

¹Per unit

Dimensions THS

Model	THS 0,75	THS 1,5	THS 3,0	THS 4,5
A, mm	30	38	45	47
B, mm	70	80	95	110
C, mm	130	165	205	235
D, mm	97	120	160	196
Ø E, mm	50	70	80	90
F, mm	12	15	20	20
G, mm	15	17	25	30
H, mm	255	335	400	450
I, mm	15	20	30	59
J, mm	135	165	195	230
K, mm	80	90	100	110
L, mm	40	50	60	64

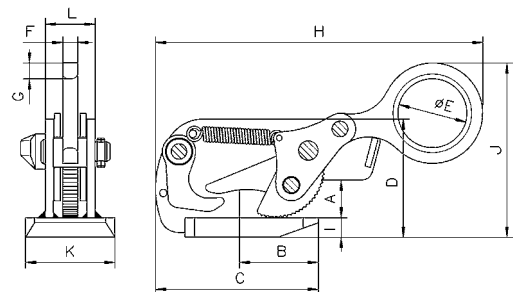

TWH Lifting clamp

Capacity 1500 - 5000 kg

The TWH lifting clamp, when used in pairs, is well-suited for horizontal transport of individual and bundled plates.

The clamp is not suited for thin plates that have a tendency to sag during transport.

It is normally used in combination with a two-legged chain sling.

The capacity (WLL) applies to a pair of lifting clamps.

Option

- Protective lining



INFO

The angle from the vertical must not exceed 45°!

Technical data TWH

Model	Art.-No.	Capacity ¹ kg	Jaw capacity mm	Weight ² kg
TWH 30 with roller	N54509101	1500	5 - 60	5.6
TWH 50 with roller	N54509102	2500	10 - 70	10.3
TWH 70 with roller	N54509103	3500	10 - 80	13.4
TWH 100 with roller	N54509104	5000	10 - 102	27.7
TWH 30 with plate	N54509105	1500	5 - 60	5.7
TWH 70 with plate	N54509107	3500	10 - 80	13.5

¹Per pair, angle from the vertical max. 45° ²Per unit

Dimensions TWH

Model	TWH 30 with roller	TWH 50 with roller	TWH 70 with roller	TWH 100 with roller	TWH 30 with plate	TWH 70 with plate
A, mm	5	10	10	10	5	10
B, mm	60	70	80	102	60	80
C, mm	60	75	90	110	60	90
D, mm	105	130	162	170	105	162
E, mm	250	315	345	425	250	345
F, mm	200	275	292	345	200	292
G, mm	31	45	55	57	22	48
H, mm	30	30	30	45	30	30
J, mm	12	12	15	20	12	15
K, mm	50	64	64	89	50	64
L, mm	73	92	92	130	73	92
Ø M, mm	18	25	25	35	18	25
N, mm	36	58	65	80	36	65
P, mm	65	77	105	120	65	105
R, mm	120	150	185	210	120	185
S, mm	100	100	100	120	100	100
T, mm	10	10	10	12	10	10

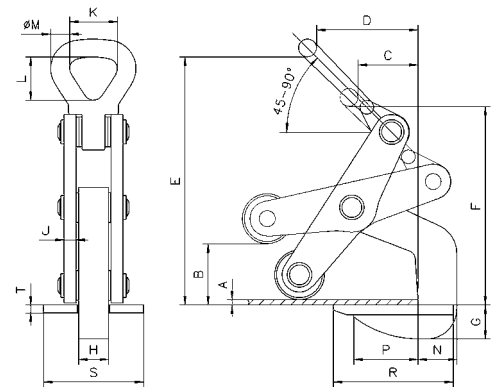

TWH with roller

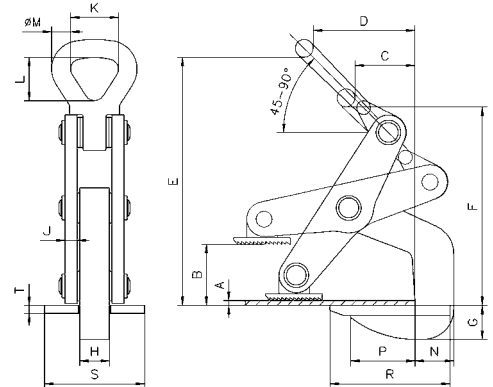

TWH with plate



THK Lifting clamp

Capacity 750 - 9000 kg

The THK lifting clamp, when used in pairs, is especially well-suited for horizontal transport of thin plates that have a tendency to sag.

It is normally used in combination with a two-legged chain sling.

The capacity applies to a pair of lifting clamps.



INFO

The angle from the vertical must not exceed 30°!

Technical data THK

Model	Art.-No.	Capacity ¹ kg	Jaw capacity mm	Weight ² kg
THK 0,75	N50701751	750	0 - 25	1.7
THK 1,5	N50701752	1500	0 - 35	3.2
THK 3,0	N50701753	3000	0 - 35	5.7
THK 4,5	N50701754	4500	0 - 45	8.4
THK 6,0	N50701755	6000	0 - 60	11.6
THK 9,0	N50701756	9000	0 - 60	17.9

¹Per pair, angle from the vertical max. 30°

²Per unit

Dimensions THK

Model	THK 0,75	THK 1,5	THK 3,0	THK 4,5	THK 6,0	THK 9,0
A, mm	25	36	38	48	63	65
B, mm	72	80	93	103	124	113
C, mm	118	135	168	183	214	223
D, mm	81	102	119	140	176	188
Ø E, mm	20	25	30	30	35	40
F, mm	161	198	227	238	284	317
G, mm	12	15	20	25	30	35
H, mm	86	102	110	122	110	148
I, mm	12	15	20	20	20	20

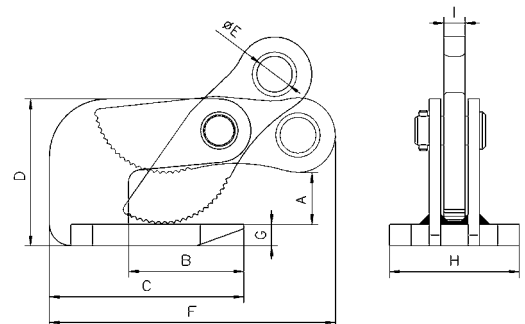

TPZ
Board clamp

Capacity 400 - 750 kg

The TPZ clamp is made for lifting and vertically transporting wood, particle board and plastic sheets.

The pliers are fastened to the plate with the aid of a hand-held lever. The jaw, which has a protective lining, grabs once lifting begins and holds the board securely.



Technical data TPZ

Model	Art.-No.	Capacity kg	Jaw capacity Z mm	Weight kg
TPZ 0,4/50	N56200001	400	5 - 50	6.3
TPZ 0,4/100	N56200002	400	50 - 100	9.0
TPZ 0,75/60	N56200003	750	5 - 60	12.0
TPZ 0,75/120	N56200004	750	60 - 120	14.0

Dimensions TPZ

Model	TPZ 0,4/50	TPZ 0,4/100	TPZ 0,75/60	TPZ 0,75/120
A, mm	120	120	155	155
B, mm	290	335	349	406
C, mm	525	525	545	560
D, mm	125	125	145	145
E, mm	117	117	135	135
F, mm	60	60	121	121
G, mm	40	40	75	75
H, mm	6	6	8 x 24	8 x 24

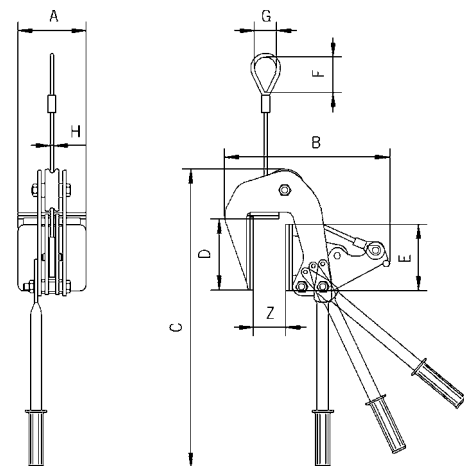

TPZ, up to 400 kg equipped with rope, from 750 kg equipped with chain.



THM Manual claw, magnetic

Capacity 120 - 170 kg

The THM manual magnetic claw is used for transporting steel sheets horizontally and vertically, lifting plates from racks, pulling steel sheets out of shelving, as well as transporting flat pieces of magnetizable steel.

The clamp, depending on the type, can be used for plate thicknesses from 1 to 5 mm.

Pressing down on the handle activates a cam which releases the magnetic claw from the workpiece.

This manual claw is maintenance-free and keeps the magnetic force for an unlimited period of time.

INFO

In order to achieve a maximum capacity, the contact surface should be bright and free from dirt, oil, grease, scale, corrosion, paint etc.

Technical data THM

Model	Art.-No.	Capacity ¹ kg	Pulling capacity ¹ kg	Weight kg
THM 120	N51602501	120	70	2
THM 170	N51602502	170	100	2

¹Measured at a safety factor 2:1 on bright drawn material St37 k

Dimensions THM

Model	THM 120	THM 170
A, mm	116	116
B, mm	140	140
C, mm	130	130
D, mm	25	25
E, mm	172	172

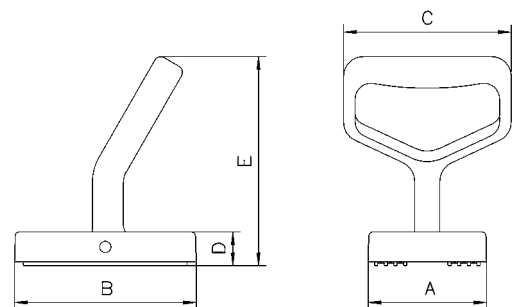

THG Hand clamp

Capacity 250 kg

The THG hand clamp is suited for the individual transport of light and thin plates. Pressing down on the hand grip releases the tension spring, allowing the clamp to open and slide onto the plate.

The plate can be transported by holding onto the ergonomically designed hand grip.

The positive spring pressure prevents the plate from accidental slipping out of the clamp.



INFO

The plate surface of the material must not exceed a hardness of HRC 30.

Technical data THG

Model	Art.-No.	Capacity kg	Jaw capacity mm	Weight kg
THG	N51502415	250	0 - 10	1.4
THG EX ¹	N4300013269	250	0 - 10	1.5
THG EB ²	N4300007661	250	0 - 10	1.4

¹ EX = Extended handle (300 mm)

² EB = Eye bolt (instead of handle)

Dimensions THG

Model	THG	THG EX	THG EB
A, mm	184	280	610
B, mm	105	105	105
C, mm	12	12	12
D, mm	53	53	53
Thickness, mm	40	40	40

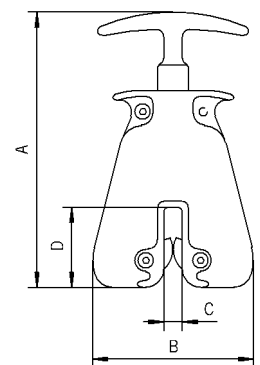

Attaching



Transport



TSH Screw clamp for vertical and horizontal pulling

Capacity 750 - 5000 kg

The screw clamp offers many possible applications. It is particularly useful for lifting, turning and pulling steel plates, girders and steel constructions.

The spindle is closed only finger tight.

Once the screw clamp is tightened and lifting begins, the pivoting pad clamping system produces a wedging action against the material, holding it securely (see below functional drawing).

Technical data TSH

Model	Art.-No.	Capacity kg	Jaw capacity Z mm	Weight kg
TSH 0,75	N51502400	750	0 - 28	3.1
TSH 1,5	N51502401	1500	0 - 32	7.4
TSH 2,0	N51502422	2000	90 - 140	14.8
TSH 2,0 S	N51502428	2000	50 - 100	14.5
TSH 3,0	N51502402	3000	0 - 50	11.4
TSH 5,0	N51502403	5000	0 - 80	27.6

Dimensions TSH

Model	TSH 0,75	TSH 1,5	TSH 2,0	TSH 2,0 S	TSH 3,0	TSH 5,0
A, mm	190	255	318	318	290	470
B, mm	52	65	74	74	74	130
Ø C, mm	19	26	30	30	30	50
D, mm	43	75	90	90	85	135
E, mm	113	130	286	246	170	225
F, mm	35	44	60	60	50	72
X, mm	15	40	38	38	40	50

INFO

The plate surface of the material must not exceed a hardness level of HRC 50.

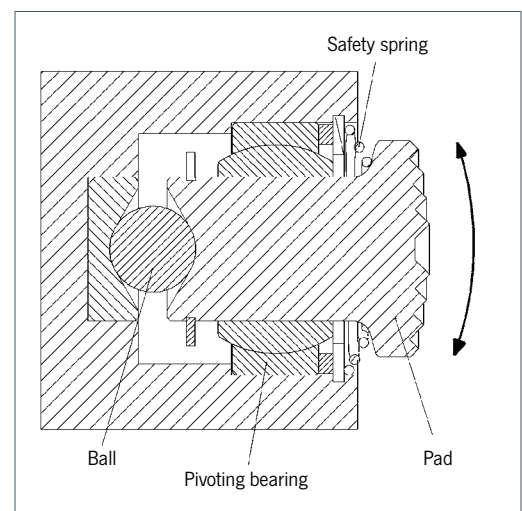
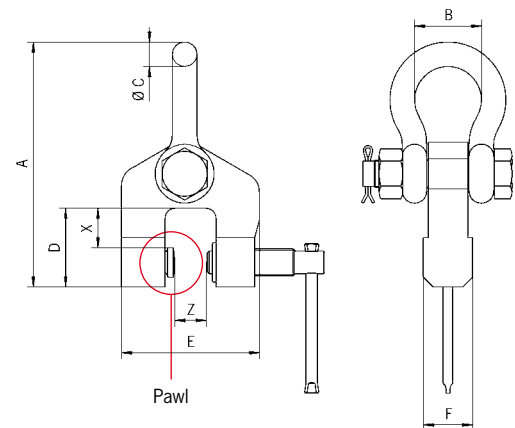

Functional drawing pivoting pad

TSZ
Screw clamp
for three-dimensional pulling

Capacity 500 - 7500 kg

The TSZ screw clamp is designed to pull in three directions. It offers many different possibilities for transporting steel constructions, feeding machining centres, etc.

The spindle is closed only finger tight.

When the screw clamp is tightened and lifting begins, the pivoting pad clamping system produces a wedging action against the material, holding it securely (see below functional drawing).



INFO

The plate surface of the material must not exceed a hardness level of HRC 50.

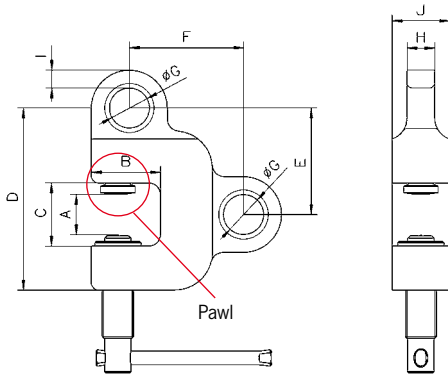

Technical data TSZ

Model	Art.-No.	Capacity kg	Jaw capacity mm	Weight kg
TSZ 0,5	N51502410	500	0 - 28	2.3
TSZ 1,5	N51502411	1500	0 - 35	5.6
TSZ 3,0	N51502412	3000	0 - 35	8.8
TSZ 5,0	N51502413	5000	0 - 40	16.2
TSZ 7,5	N51502414	7500	0 - 40	20.9

Dimensions TSZ

Model	TSZ 0,5	TSZ 1,5	TSZ 3,0	TSZ 5,0	TSZ 7,5
A, mm	28	35	35	40	40
B, mm	43	60	67	85	92
C, mm	45	55	65	75	75
D, mm	125	158	195	230	240
E, mm	72	93	114	133	143
F, mm	83	99	120	150	162
Ø G, mm	26	35	46	55	65
H, mm	16	24	34	40	50
I, mm	12	16	17	18	23
J, mm	35	50	60	75	80

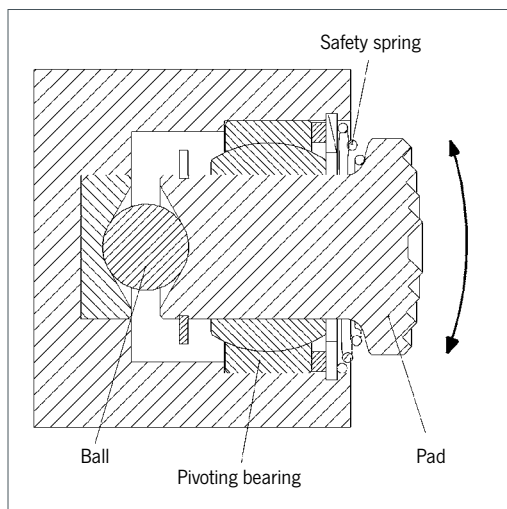

Functional drawing pivoting pad

TRU Roundstock grab

Capacity 100 - 4000 kg

The TRU roundstock grab picks up roundstock and pipe material up to 600 mm in diameter quickly and safely. With its optional protective lining, it can also pick up materials with sensitive surfaces.

INFO

When using protective lining, it is important that the surfaces are dry, clean and free of oil and grease.



Technical data TRU

Model	Art.-No.	Art.-No. with protective lining	Capacity kg	Jaw capacity Z mm	Weight kg
TRU 0,1/150	N51902711	N51902712	100	50 - 150	4.2
TRU 0,5/200	N51902701	N51902706	500	35 - 200	13.6
TRU 1,0/200	N51902702	N51902707	1000	35 - 200	13.6
TRU 1,5/300	N51902703	N51902708	1500	80 - 300	27.0
TRU 3,0/300	N51902704	N51902709	3000	80 - 300	49.0
TRU 4,0/600	N51902705	N51902710	4000	200 - 600	204.0

Dimensions TRU

Model	TRU 0,1/150	TRU 0,5/200	TRU 1,0/200	TRU 1,5/300	TRU 3,0/300	TRU 4,0/600
A, mm	270	503	509	720	740	1420
B min., mm	292	417	437	520	582	930
B max., mm	458	723	745	937	960	1815
C, mm	97	150	178	204	220	318
D, mm	43	56	82	84	125	205
E, mm	8	15	15	20	20	30
F, mm	17	17	30	25	30	35

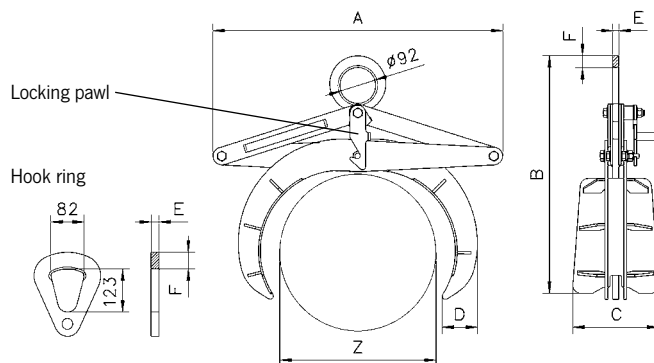

TRU, hook ring for grabs for 2000 kg and above.
Locking pawl keeps the grab in the open position.

TPR
Profile steel grab

Capacity 500 - 3000 kg

The TPR steel grab is designed for transport of girders, profile steel, etc. It boasts a large jaw capacity, which makes it useful for various flange widths.

The clamping jaws press securely with a positive fit to the girder.



Technical data TPR

Model	Art.-No.	Capacity kg	Jaw capacity Z mm	Weight kg
TPR 0,5/200	N51802601	500	0 - 200	15.0
TPR 1,5/300	N51802602	1500	0 - 300	22.6
TPR 3,0/300	N51802603	3000	0 - 300	41.7

Dimensions TPR

Model	TPR 0,5/200	TPR 1,5/300	TPR 3,0/300
A, mm	510	710	720
B min., mm	390	495	525
B max., mm	625	830	920
C, mm	200	200	220
D, mm	15	15	20
E, mm	30	30	43

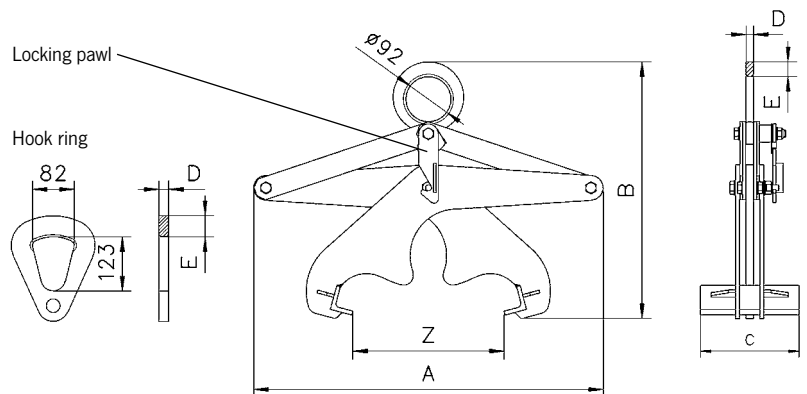

Hook ring for grabs for 2000 kg and above.
Locking pawl keeps the grab in the open position.



TVB Block grab

Capacity 250 and 500 kg

The TVB block grab is useful for the transport of stone and concrete blocks and other materials with parallel surfaces. The grab has a protective lining to ensure a safe and non-marring transport.

The clamping jaw and the center of gravity are easily and quickly adjustable by means of the locking pin.

INFO

It is important that the surfaces are dry, clean and free of oil and grease.

Technical data TVB

Model	Art.-No.	Capacity kg	Jaw capacity Z mm	Weight kg
TVB 500	N52625000	250/500	0 - 240	13

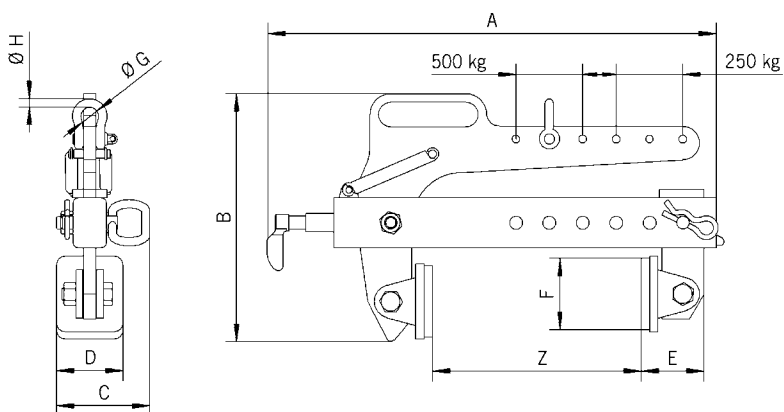

Dimensions TVB

Model	TVB 500
A, mm	537
B, mm	296
C, mm	112
D, mm	80
E, mm	75
F, mm	85
Ø G, mm	22
Ø H, mm	10



TBG
Concrete grab

Capacity 500 - 1000 kg

The TBG block grabs are suited for the transport of all materials with parallel surfaces that can withstand a clamping pressure twice as high as the load being lifted.

The grabs are delivered with a replaceable hard rubber protective lining as standard.



Concrete grab with large jaw capacity



Concrete grab with small jaw capacity



Technical data TBG with small and large jaw capacity

Model	Art.-No.	Capacity kg	Jaw capacity Z mm	Weight kg
TBG 0,5/150	N52604009	500	0 - 150	27
TBG 1,0/250	N52604010	1000	50 - 250	50
TBG 0,2/500	N52604156	200	200 - 500	49
TBG 0,3/700	N52604157	300	400 - 700	52
TBG 0,5/900	N52604158	500	600 - 900	55
TBG 1,0/400	N52704251	1000	100 - 400	51
TBG 1,0/1100	N52604159	1000	800 - 1100	72

INFO

When using rubber protective lining it is important that the surfaces are dry, clean and free of oil and grease.

Dimensions TBG with small and large jaw capacity

Model	TBG 0,5/150	TBG 1,0/250	TBG 0,2/500	TBG 0,3/700	TBG 0,5/900	TBG 1,0/400	TBG 1,0/1100
A ¹ , mm	815	1050	1040	1040	1120	1040	1320
B min., mm	420	460	390	390	390	390	390
B max., mm	760	980	840	840	840	840	840
C, mm	200	250	275	275	275	250	275
D, mm	160	160	160	160	160	160	160
E, mm	30	29	300	300	300	300	300
F, mm	15	20	35	35	35	35	35
G, mm	-	-	20	20	20	20	20

¹ Scissor dimensions

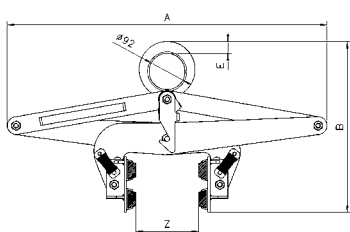

Concrete grab with small jaw capacity

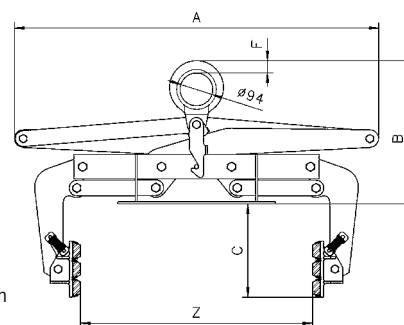
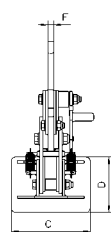

Concrete grab with large jaw capacity

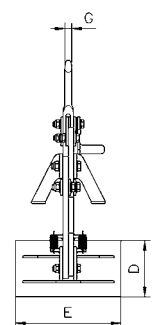



TBA Bale grab

Capacity 200 - 1000 kg

The TBA bale grab transports bales of fiber, wool, fabric, paper, pressed straw and various types of shavings up to a width of 1.3 m. Bales are gripped safely yet gently, and where applicable, the clamps are lined with a soft and pliable material.

The locking pawl only engages if the grab is opened without manual intervention.

INFO

The standard grab is equipped with protective linings.

Serrated jaws available on request.

Technical data TBA

Model	Art.-No. with protective lining	Capacity kg	Jaw capacity Z mm	Weight kg
TBA 0,2/700	N52804501	200	250 - 700	40
TBA 0,3/900	N52804502	300	450 - 900	42
TBA 0,5/1100	N52804503	500	650 - 1100	45
TBA 0,75/1300	N52804504	750	850 - 1300	62
TBA 1,0/1300	N52804505	1000	850 - 1300	62

Dimensions TBA

Model	TBA 0,2/700	TBA 0,3/900	TBA 0,5/1100	TBA 0,75/1300	TBA 1,0/1300
A, mm	890	1090	1290	1550	1550
B, mm	420	420	420	420	420
C, mm	500	500	500	500	500
D, mm	35	35	35	35	35
E, mm	20	20	20	20	20

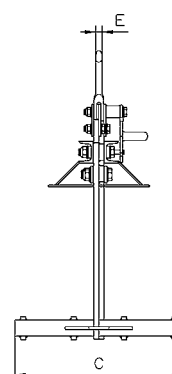
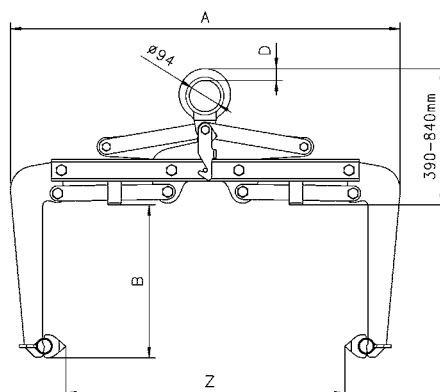

TBA 0.2-1t with serrated jaw

TCR

Rail grab with safety lock

Capacity 1000 - 2000 kg

The TCR rail grab transports rails, as used by railways, easily and safely. A safe grip is ensured by the lever operated safety lock. For long rails, two grabs must be attached to a spreader beam to avoid sagging.

Since the rails are primarily grabbed with positive fit, it is important that the clamp stays in a vertical position during initial lift.



Technical data TCR

Model	Art.-No.	Capacity kg	Weight kg
TCR 1,0	N51402351	1000	12.4
TCR 2,0	N51402352	2000	13.9

Dimensions TCR

Model	TCR 1,0	TCR 2,0
A ¹ , mm	144	144
B, mm	152	163
C, mm	350	350
D, mm	90	90
E, mm	46	46
Ø F, mm	20	20
G, mm	25	25

¹Scissor dimensions

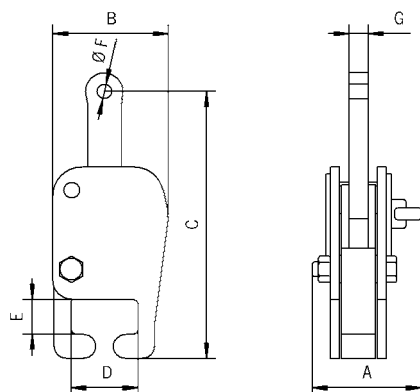

INFO

For special sizes please advise rail type and profile!

A TCR multiple rail system is also available for the simultaneous transport of up to 12 rails.

For rail jacks please see page 124.